



SGM3005

Ultra Low ON-Resistance, Low Voltage, Dual, SPDT Analog Switch

GENERAL DESCRIPTION

The SGM3005 is a dual, low on-resistance, low voltage, bidirectional, single-pole/double-throw (SPDT) CMOS analog switch designed to operate from a single 1.8V to 5.5V power supply. Targeted applications include battery powered equipment that benefit from low R_{ON} (0.5Ω) and fast switching speeds ($t_{ON} = 50ns$, $t_{OFF} = 15ns$).

The on resistance profile is very flat over the full analog signal range. This ensures excellent linearity and low distortion when switching audio signals.

The SGM3005 is a committed dual single-pole/double-throw (SPDT) that consist of two normally open (NO) and two normally close (NC) switches. This configuration can be used as a dual 2-to-1 multiplexer.

SGM3005 is available in Green TDFN-3x3-10L and MSOP-10 packages.

APPLICATIONS

- Battery-powered, Handheld, and Portable Equipment
 - Cellular/Mobile Phones
 - Laptops, Notebooks, Palmtops
- Communication Systems
- Sample-and-Hold Circuits
- Audio Signal Routing
- Audio and Video Switching
- Portable Test and Measurement
- Medical Equipment

FUNCTION TABLE

LOGIC	NC1, NC2	NO1, NO2
0	ON	OFF
1	OFF	ON

FEATURES

- **Low Voltage Operation: 1.8V to 5.5V**
- **Low On-Resistance: 0.5Ω (TYP)**
- **Low On-Resistance Flatness**
- **-3dB Bandwidth: 15MHz**
- **Fast Switching Times**
 - t_{ON} 50ns
 - t_{OFF} 15ns
- **Rail-to-Rail Operation**
- **Typical Power Consumption ($< 0.01\mu W$)**
- **TTL/CMOS Compatible**
- **Microsize Packages**

PIN CONFIGURATIONS (TOP VIEW)

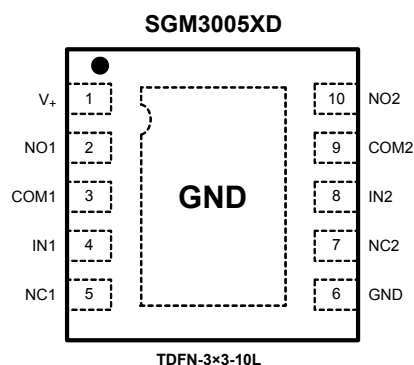
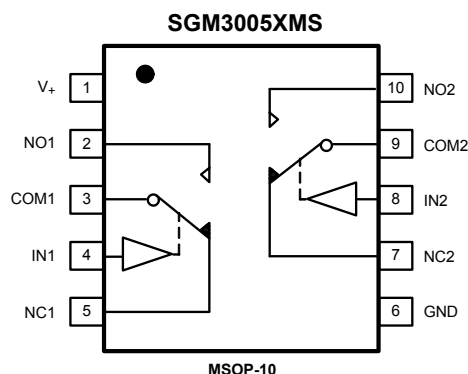

PACKAGE/ORDERING INFORMATION

MODEL	PIN-PACKAGE	SPECIFIED TEMPERATURE RANGE	ORDERING NUMBER	PACKAGE MARKING	PACKAGE OPTION
SGM3005	MSOP-10	-40°C to +125°C	SGM3005XMS/TR	SGM3005XMS	Tape and Reel, 3000
	TDFN-3×3-10L	-40°C to +125°C	SGM3005XD/TR	SGM3005D	Tape and Reel, 3000

ABSOLUTE MAXIMUM RATINGS

V ₊ to GND.....	-0.3V to 6V	Package Thermal Resistance @ T _A = 25°C	
Analog, Digital voltage range ⁽¹⁾	-0.3V to (V ₊) + 0.3V	TDFN-3×3-10L, θ _{JA}	33°C/W
Continuous Current NO, NC, or COM.....	±300mA	MSOP-10, θ _{JA}	205°C/W
Peak Current NO, NC, or COM.....	±500mA	Lead Temperature (soldering, 10s).....	260°C
Operating Temperature Range	-40°C to +125°C	ESD Susceptibility	
Junction Temperature	150°C	HBM.....	2000V
Storage Temperature Range.....	-65°C to +150°C	MM.....	400V

NOTES:

1. Signals on NC, NO, or COM or IN exceeding V₊ will be clamped by internal diodes. Limit forward diode current to maximum current ratings.
2. Stresses beyond those listed under “Absolute Maximum Ratings” may cause permanent damage to the device. These are stress ratings only, and functional operation of the device at these or any other conditions beyond those indicated in the operational sections of the specifications is not implied. Exposure to absolute maximum rating conditions for extended periods may affect device reliability.

CAUTION

This integrated circuit can be damaged by ESD if you don't pay attention to ESD protection. SGMICRO recommends that all integrated circuits be handled with appropriate precautions. Failure to observe proper handling and installation procedures can cause damage. ESD damage can range from subtle performance degradation to complete device failure. Precision integrated circuits may be more susceptible to damage because very small parametric changes could cause the device not to meet its published specifications.

SGMICRO reserves the right to make any change in circuit design, specification or other related things if necessary without notice at any time. Please contact SGMICRO sales office to get the latest datasheet.

PIN DESCRIPTION

NAME	PIN	FUNCTION
V ₊	1	Power Supply.
GND	6	Ground.
IN1, IN2	4, 8	Digital Control Pin to Connect the COM Terminal to the NO or NC Terminals.
COM1, COM2	3, 9	Common Terminal.
NO1, NO2	2, 10	Normally-Open Terminal.
NC1, NC2	5, 7	Normally-Closed Terminal.

NOTE: NO, NC and COM terminals may be an input or output.

SGM3005

Ultra Low ON-Resistance, Low Voltage, Dual, SPDT Analog Switch

ELECTRICAL CHARACTERISTICS

($V_+ = +5V \pm 10\%$, $GND = 0V$, $T_A = -40^\circ C$ to $+125^\circ C$, typical values are at $T_A = +25^\circ C$, unless otherwise noted.)

PARAMETER	SYMBOL	CONDITIONS	SGM3005			
			+25°C	-40°C to +125°C	UNITS	MIN/MAX
ANALOG SWITCH						
Analog Signal Range	V_{NO}, V_{NC}, V_{COM}			0	V	MIN
				V_+	V	MAX
On-Resistance	R_{ON}	$0 \leq V_{NO}$ or $V_{NC} \leq V_+$, $I_{COM} = -10mA$, Test Circuit 1	0.5		Ω	TYP
			0.9	1.1	Ω	MAX
On-Resistance Match Between Channels	ΔR_{ON}	$0 \leq V_{NO}$ or $V_{NC} \leq V_+$, $I_{COM} = -10mA$, Test Circuit 1	0.05		Ω	TYP
			0.09	0.12	Ω	MAX
On-Resistance Flatness	$R_{FLAT(ON)}$	$0 \leq V_{NO}$ or $V_{NC} \leq V_+$, $I_{COM} = -10mA$, Test Circuit 1	0.25		Ω	TYP
			0.3	0.4	Ω	MAX
LEAKAGE CURRENTS						
Source OFF Leakage Current	$I_{NC(OFF)}, I_{NO(OFF)}$	V_{NO} or $V_{NC} = 4.5V/1V$, $V_{COM} = 1V/4.5V$, $V_+ = +5.5V$, Test Circuit 2	± 4		nA	TYP
			± 10	± 1000	nA	MAX
Channel ON Leakage Current	$I_{NC(ON)}, I_{NO(ON)}, I_{COM(ON)}$	V_{NO} or $V_{NC} = V_{COM} = 1V$ or $4.5V$, $V_+ = +5.5V$, Test Circuit 3	± 4		nA	TYP
			± 10	± 1000	nA	MAX
DIGITAL INPUTS						
Input High Voltage	V_{INH}			2.4	V	MIN
Input Low Voltage	V_{INL}			0.8	V	MAX
Input Current	I_{INL} or I_{INH}	$V_{IN} = V_{INH}$ or V_{INL}	± 0.01		μA	TYP
			± 0.1	± 1	μA	MAX
DYNAMIC CHARACTERISTICS						
Turn-On Time	t_{ON}	V_{NO} or $V_{NC} = 3V$, $R_L = 300\Omega$, $C_L = 35pF$, Test Circuit 4	50		ns	TYP
Turn-Off Time	t_{OFF}	V_{NO} or $V_{NC} = 3V$, $R_L = 300\Omega$, $C_L = 35pF$, Test Circuit 4	15		ns	TYP
Charge Injection	Q	$C_L = 1.0nF$, $V_G = 0V$, $R_G = 0\Omega$, Test Circuit 5	20		pC	TYP
Break-Before-Make Time Delay	t_D	V_{NO1} or $V_{NC1} = V_{NO2}$ or $V_{NC2} = 3V$, $R_L = 300\Omega$, $C_L = 35pF$, Test Circuit 6	10		ns	TYP
Off Isolation	O_{ISO}	$R_L = 50\Omega$, $C_L = 5pF$, Test Circuit 7	f = 100kHz	-69	dB	TYP
			f = 10kHz	-85	dB	TYP
Channel-to-Channel Crosstalk	X_{TALK}	$R_L = 50\Omega$, $C_L = 5pF$, Test Circuit 8	f = 100kHz	-90	dB	TYP
			f = 10kHz	-105	dB	TYP
Total Harmonic Distortion	THD	f = 20Hz to 20kHz, $V_{COM} = 3.5V_{P-P}$, $R_L = 600\Omega$, $C_L = 50pF$	0.065		%	TYP
-3dB Bandwidth	BW	$R_L = 50\Omega$, $C_L = 5pF$, Test Circuit 9	15		MHz	TYP
Source OFF Capacitance	$C_{NC(OFF)}, C_{NO(OFF)}$		82		pF	TYP
Channel ON Capacitance	$C_{NC(ON)}, C_{NO(ON)}, C_{COM(ON)}$		380		pF	TYP
POWER REQUIREMENTS						
Power Supply Current	I_+	$V_+ = +5.5V$, $V_{IN} = 0V$ or $5V$	0.001		μA	TYP
				1	μA	MAX

SGM3005

Ultra Low ON-Resistance, Low Voltage, Dual, SPDT Analog Switch

ELECTRICAL CHARACTERISTICS

($V_+ = +3V \pm 10\%$, $GND = 0V$, $T_A = -40^\circ C$ to $+125^\circ C$, typical values are at $T_A = +25^\circ C$, unless otherwise noted.)

PARAMETER	SYMBOL	CONDITIONS	SGM3005			
			+25°C	-40°C to +125°C	UNITS	MIN/MAX
ANALOG SWITCH						
Analog Signal Range	V_{NO}, V_{NC}, V_{COM}			0	V	MIN
				V_+	V	MAX
On-Resistance	R_{ON}	$0 \leq V_{NO}$ or $V_{NC} \leq V_+$, $I_{COM} = -10mA$, Test Circuit 1	0.6		Ω	TYP
			1.0	1.3	Ω	MAX
On-Resistance Match Between Channels	ΔR_{ON}	$0 \leq V_{NO}$ or $V_{NC} \leq V_+$, $I_{COM} = -10mA$, Test Circuit 1	0.05		Ω	TYP
			0.1	0.13	Ω	MAX
On-Resistance Flatness	$R_{FLAT(ON)}$	$0 \leq V_{NO}$ or $V_{NC} \leq V_+$, $I_{COM} = -10mA$, Test Circuit 1	0.25		Ω	TYP
			0.3	0.4	Ω	MAX
LEAKAGE CURRENTS						
Source OFF Leakage Current	$I_{NC(OFF)}, I_{NO(OFF)}$	V_{NO} or $V_{NC} = 3V/1V$, $V_{COM} = 1V/3V$, $V_+ = +3.3V$, Test Circuit 2	± 5		nA	TYP
			± 11	± 1000	nA	MAX
Channel ON Leakage Current	$I_{NC(ON)}, I_{NO(ON)}, I_{COM(ON)}$	V_{NO} or $V_{NC} = V_{COM} = 1V$ or $3V$, $V_+ = +3.3V$, Test Circuit 3	± 5		nA	TYP
			± 11	± 1000	nA	MAX
DIGITAL INPUTS						
Input High Voltage	V_{INH}			2.0	V	MIN
Input Low Voltage	V_{INL}			0.4	V	MAX
Input Current	I_{INL} or I_{INH}	$V_{IN} = V_{INH}$ or V_{INL}	± 0.01		μA	TYP
			± 0.1	± 1	μA	MAX
DYNAMIC CHARACTERISTICS						
Turn-On Time	t_{ON}	V_{NO} or $V_{NC} = 2V$, $R_L = 300\Omega$, $C_L = 35pF$, Test Circuit 4	50		ns	TYP
Turn-Off Time	t_{OFF}	V_{NO} or $V_{NC} = 2V$, $R_L = 300\Omega$, $C_L = 35pF$, Test Circuit 4	17		ns	TYP
Charge Injection	Q	$C_L = 1.0nF$, $V_G = 0V$, $R_G = 0\Omega$, Test Circuit 5	25		pC	TYP
Break-Before-Make Time Delay	t_D	V_{NO1} or $V_{NC1} = V_{NO2}$ or $V_{NC2} = 2V$, $R_L = 300\Omega$, $C_L = 35pF$, Test Circuit 6	11		ns	TYP
Off Isolation	O_{ISO}	$R_L = 50\Omega$, $C_L = 5pF$, Test Circuit 7	f = 100kHz	-69	dB	TYP
			f = 10kHz	-85	dB	TYP
Channel-to-Channel Crosstalk	X_{TALK}	$R_L = 50\Omega$, $C_L = 5pF$, Test Circuit 8	f = 100kHz	-90	dB	TYP
			f = 10kHz	-105	dB	TYP
Total Harmonic Distortion	THD	f = 20Hz to 20kHz, $V_{COM} = 2V_{P-P}$, $R_L = 600\Omega$, $C_L = 50pF$	0.06		%	TYP
-3dB Bandwidth	BW	$R_L = 50\Omega$, $C_L = 5pF$, Test Circuit 9	15		MHz	TYP
Source OFF Capacitance	$C_{NC(OFF)}, C_{NO(OFF)}$		82		pF	TYP
Channel ON Capacitance	$C_{NC(ON)}, C_{NO(ON)}, C_{COM(ON)}$		380		pF	TYP
POWER REQUIREMENTS						
Power Supply Current	I_+	$V_+ = +3.3V$, $V_{IN} = 0V$ or $3V$	0.001		μA	TYP
				1	μA	MAX

TYPICAL PERFORMANCE CHARACTERISTICS

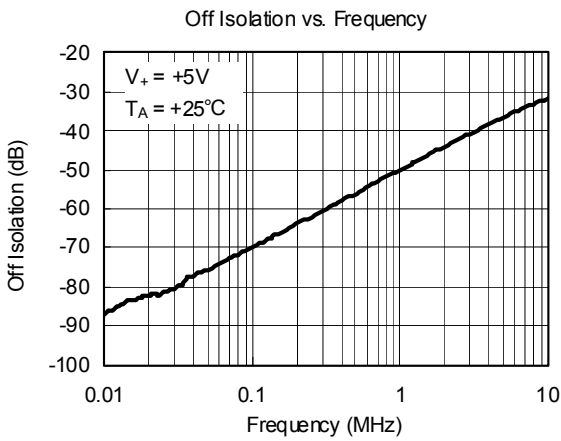
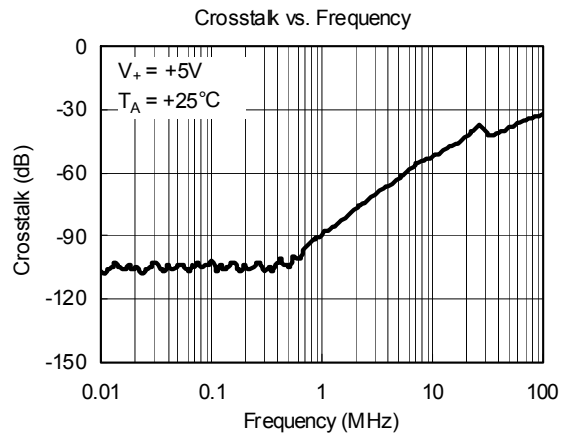
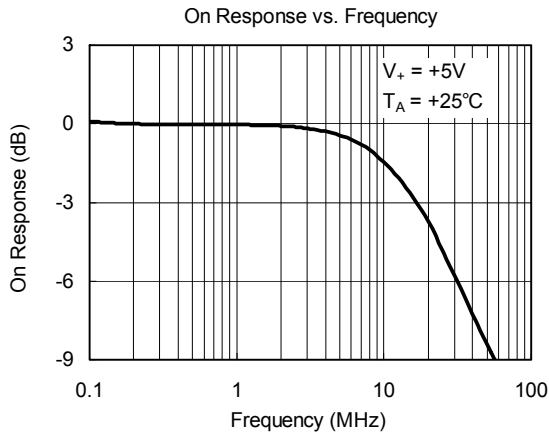

TEST CIRCUITS

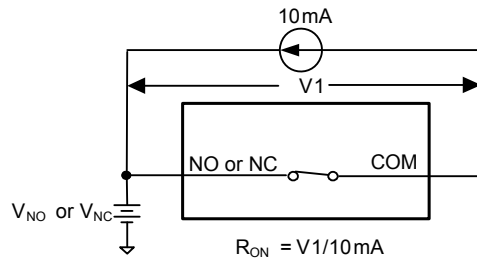

Test Circuit 1. On Resistance

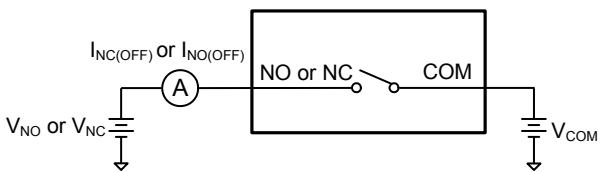

Test Circuit 2. Off Leakage

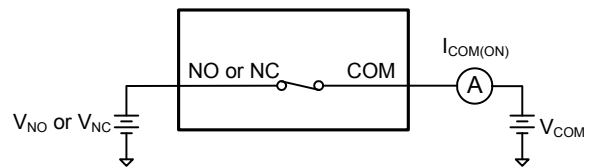

Test Circuit 3. On Leakage

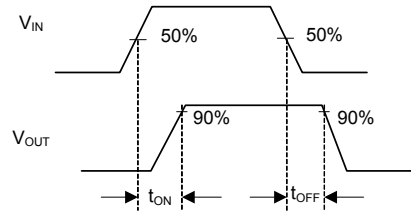
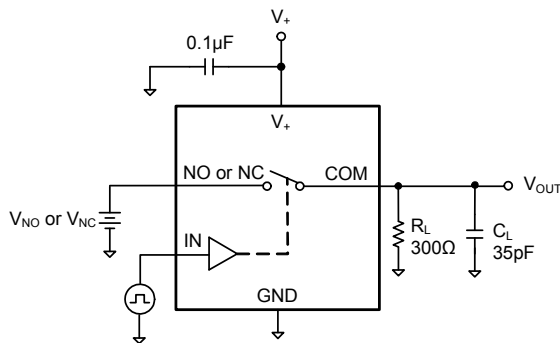

Test Circuit 4. Switching Times

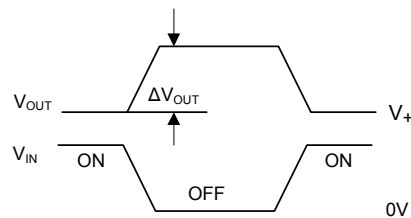
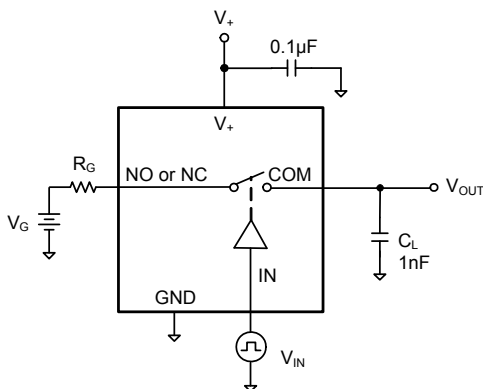

Test Circuit 5. Charge Injection

TEST CIRCUITS (Cont.)

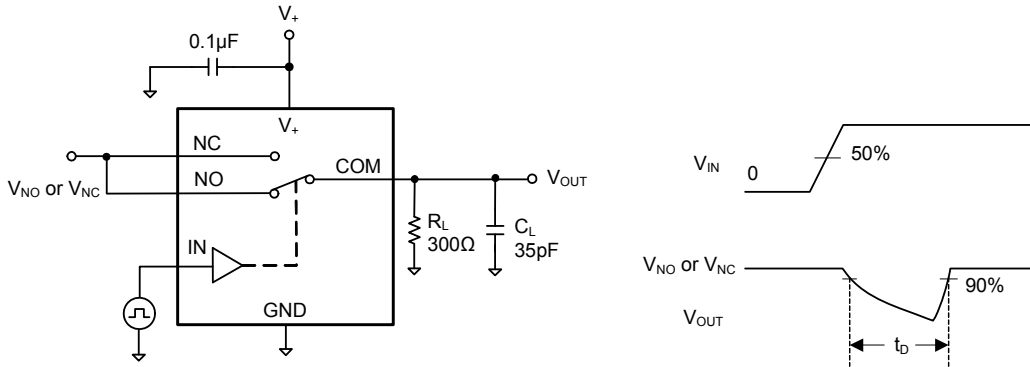

Test Circuit 6. Break-Before-Make Time Delay, t_D

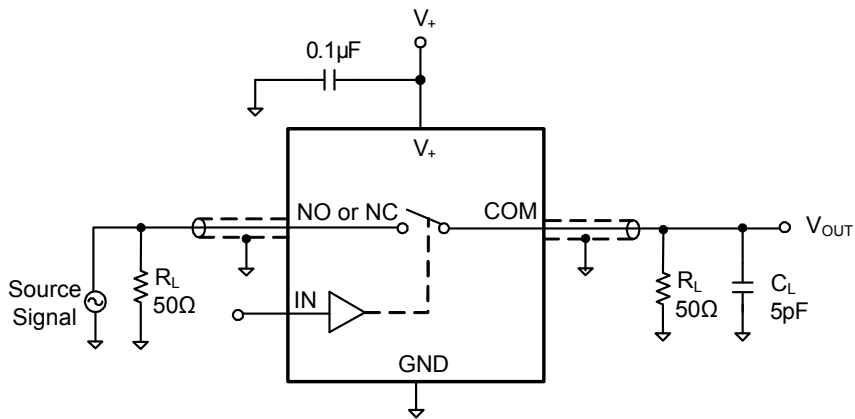

Test Circuit 7. Off Isolation

TEST CIRCUITS (Cont.)

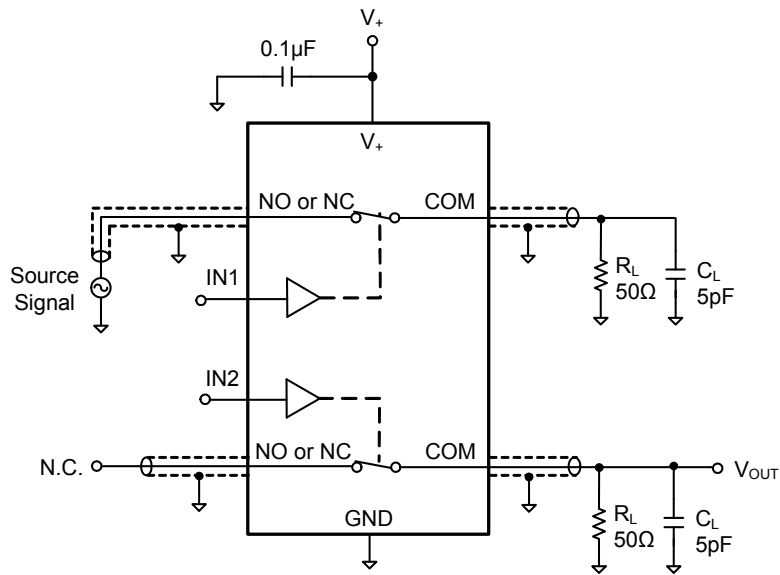

$$\text{Channel To Channel Crosstalk} = -20 \times \log \frac{V_{NO \text{ or } V_{NC}}}{V_{OUT}}$$

Test Circuit 8. Channel-to-Channel Crosstalk

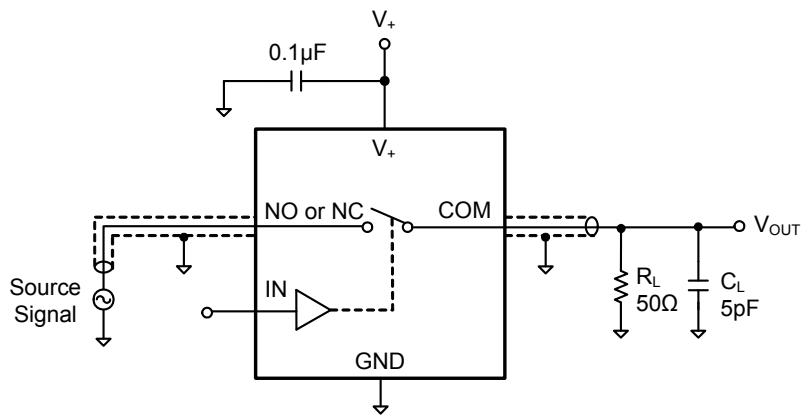

Test Circuit 9. -3dB Bandwidth

PACKAGE OUTLINE DIMENSIONS

TDFN-3x3-10L

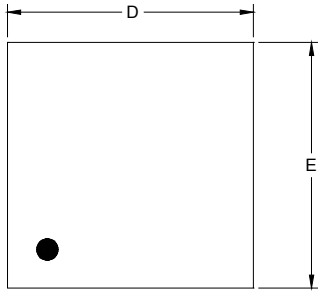

TOP VIEW

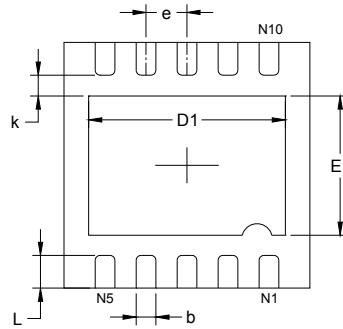

BOTTOM VIEW

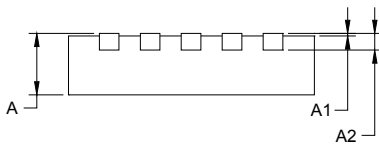

SIDE VIEW

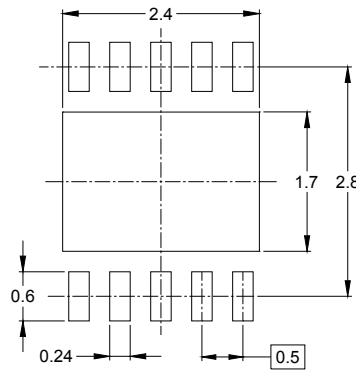

RECOMMENDED LAND PATTERN (Unit: mm)

Symbol	Dimensions In Millimeters		Dimensions In Inches	
	MIN	MAX	MIN	MAX
A	0.700	0.800	0.028	0.031
A1	0.000	0.050	0.000	0.002
A2	0.203 REF		0.008 REF	
D	2.900	3.100	0.114	0.122
D1	2.300	2.600	0.091	0.103
E	2.900	3.100	0.114	0.122
E1	1.500	1.800	0.059	0.071
k	0.200 MIN		0.008 MIN	
b	0.180	0.300	0.007	0.012
e	0.500 TYP		0.020 TYP	
L	0.300	0.500	0.012	0.020

PACKAGE OUTLINE DIMENSIONS

MSOP-10

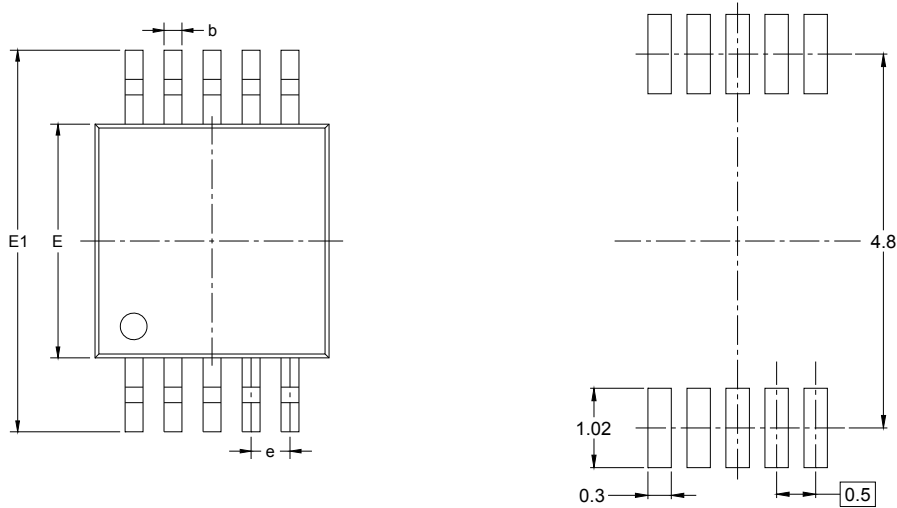

RECOMMENDED LAND PATTERN (Unit: mm)

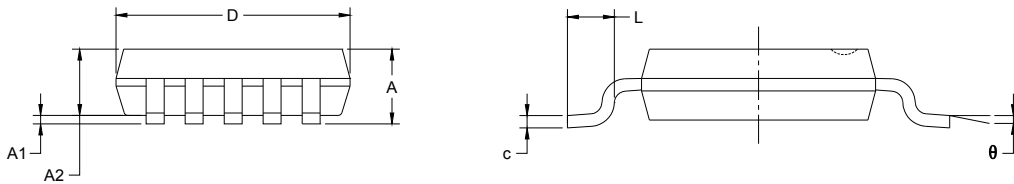

Symbol	Dimensions In Millimeters		Dimensions In Inches	
	MIN	MAX	MIN	MAX
A	0.820	1.100	0.032	0.043
A1	0.020	0.150	0.001	0.006
A2	0.750	0.950	0.030	0.037
b	0.180	0.280	0.007	0.011
c	0.090	0.230	0.004	0.009
D	2.900	3.100	0.114	0.122
E	2.900	3.100	0.114	0.122
E1	4.750	5.050	0.187	0.199
e	0.500 BSC		0.020 BSC	
L	0.400	0.800	0.016	0.031
θ	0°	6°	0°	6°

TAPE AND REEL INFORMATION

REEL DIMENSIONS

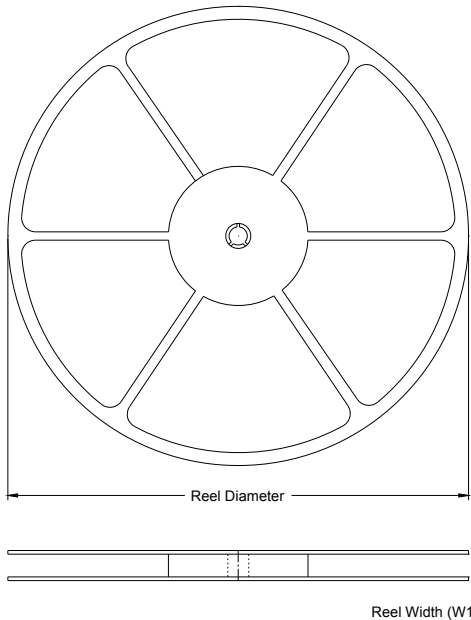

TAPE DIMENSIONS

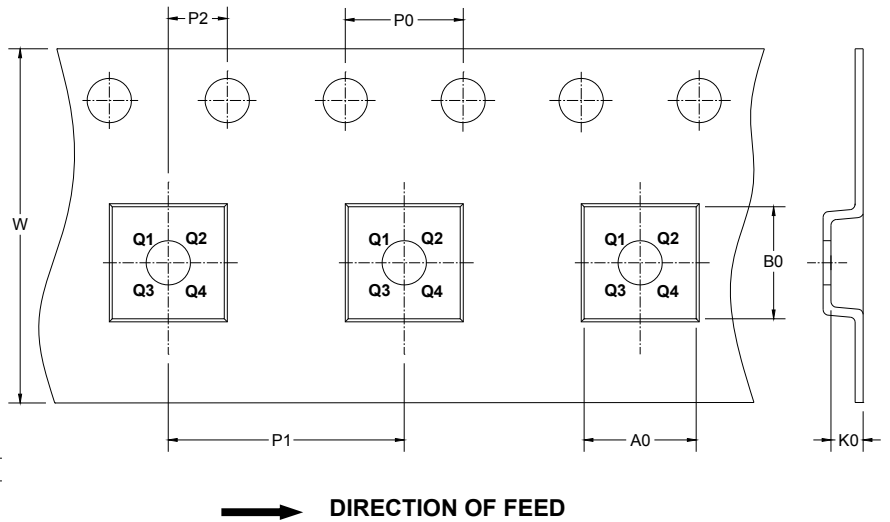

NOTE: The picture is only for reference. Please make the object as the standard.

KEY PARAMETER LIST OF TAPE AND REEL

Package Type	Reel Diameter	Reel Width W1 (mm)	A0 (mm)	B0 (mm)	K0 (mm)	P0 (mm)	P1 (mm)	P2 (mm)	W (mm)	Pin1 Quadrant
MSOP-10	13"	12.4	5.2	3.3	1.2	4.0	8.0	2.0	12.0	Q1
TDFN-3×3-10L	13"	12.4	3.35	3.35	1.13	4.00	8.00	2.00	12.00	Q1

SGM3005

Ultra Low ON-Resistance, Low Voltage, Dual, SPDT Analog Switch

CARTON BOX DIMENSIONS

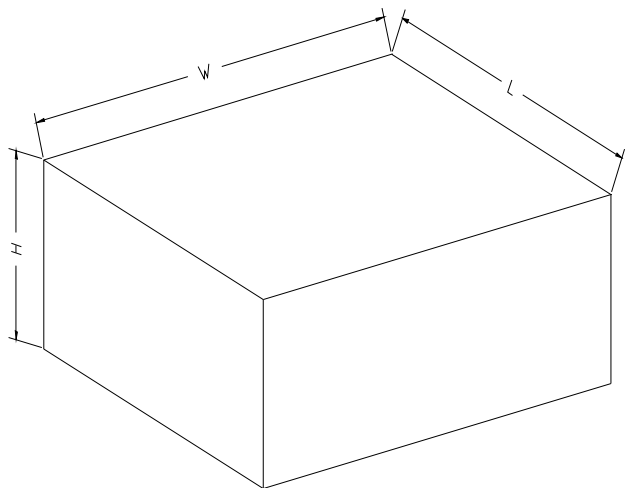

NOTE: The picture is only for reference. Please make the object as the standard.

KEY PARAMETER LIST OF CARTON BOX

Reel Type	Length (mm)	Width (mm)	Height (mm)	Pizza/Carton
13"	386	280	370	5